

# NS112 Temperature

## Analog Ambient Temperature Sensor

- Linear Active Temperature Monitor
- 0-10V Analog or Digital Output
- Adjustable Sensitivity
- 12-24V 50mA DC Supply
- 3 Wire Screw Terminal



## Overview

The NS112 Temperature sensor is a simple low voltage analog ambient temperature detector. It can easily integrate into an existing building control system. Connect the sensor output signal to an analog input of a controller, gateway, or data acquisition unit. The temperature signal can be used for automation such thermostats or zonal modulation of ventilation and other heating and cooling controls.

## Operation

The sensor can detect temperature of local airspace. The device is suitable for ceiling or wall mount applications. Place the sensor in a suitable location where local temperature should be detected.

The sensitivity can be adjusted with a simple jumper position. This selection changes the gain of an analog amplifier. Choose a gain suitable for typical temperature range. A high gain will detect lower levels. Whereas a lower gain will minimize noise in the signal.

The output mode can be changed from a continuously varying analog signal to a digital signal. The digital signal is produced by a comparator with a threshold at half scale (i.e. 5V) or quarter scale (i.e. 2.5V). Use the analog mode to continuously monitor levels. Or use the digital mode to trigger actuators at a specific event threshold.

Changing the sensitivity and choosing the digital output scale can adjust the event threshold. Setting sensitivity high and digital scale low will reduce the event threshold to a minimum and detect the smallest changes in levels. Whereas, setting sensitivity low and digital scale high will increase the threshold to a maximum and detect only the largest changes in levels.

## Detection Level

The temperature detection level would be used typically in analog mode. The raw temperature value would be fed back to a temperature controller which would modulate some control like a fan speed or heating or cooling relay circuit. However, the sensor is equipped with a digital mode that could indicate an excessively high or low temperature event.

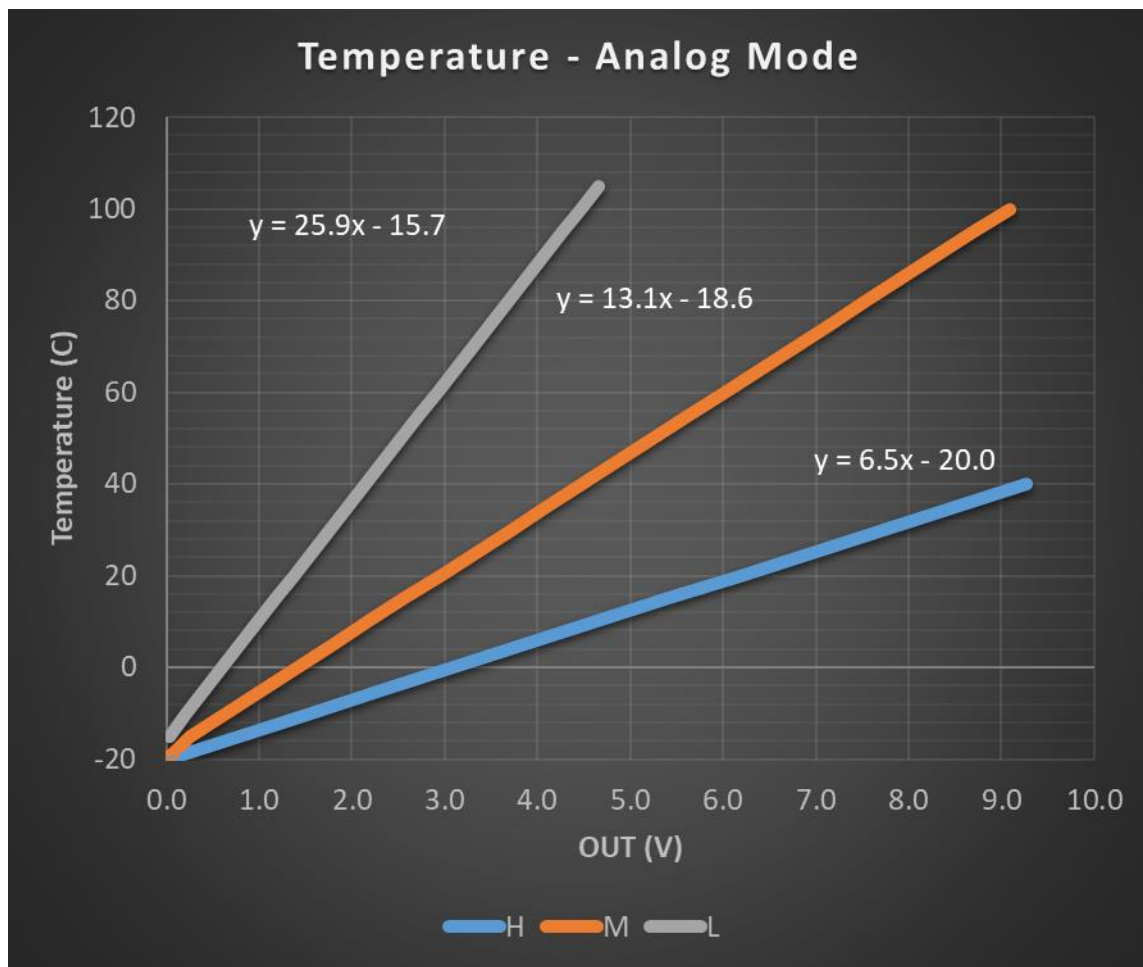

1 Temperature Analog Mode for H, M, and L Sensitivities

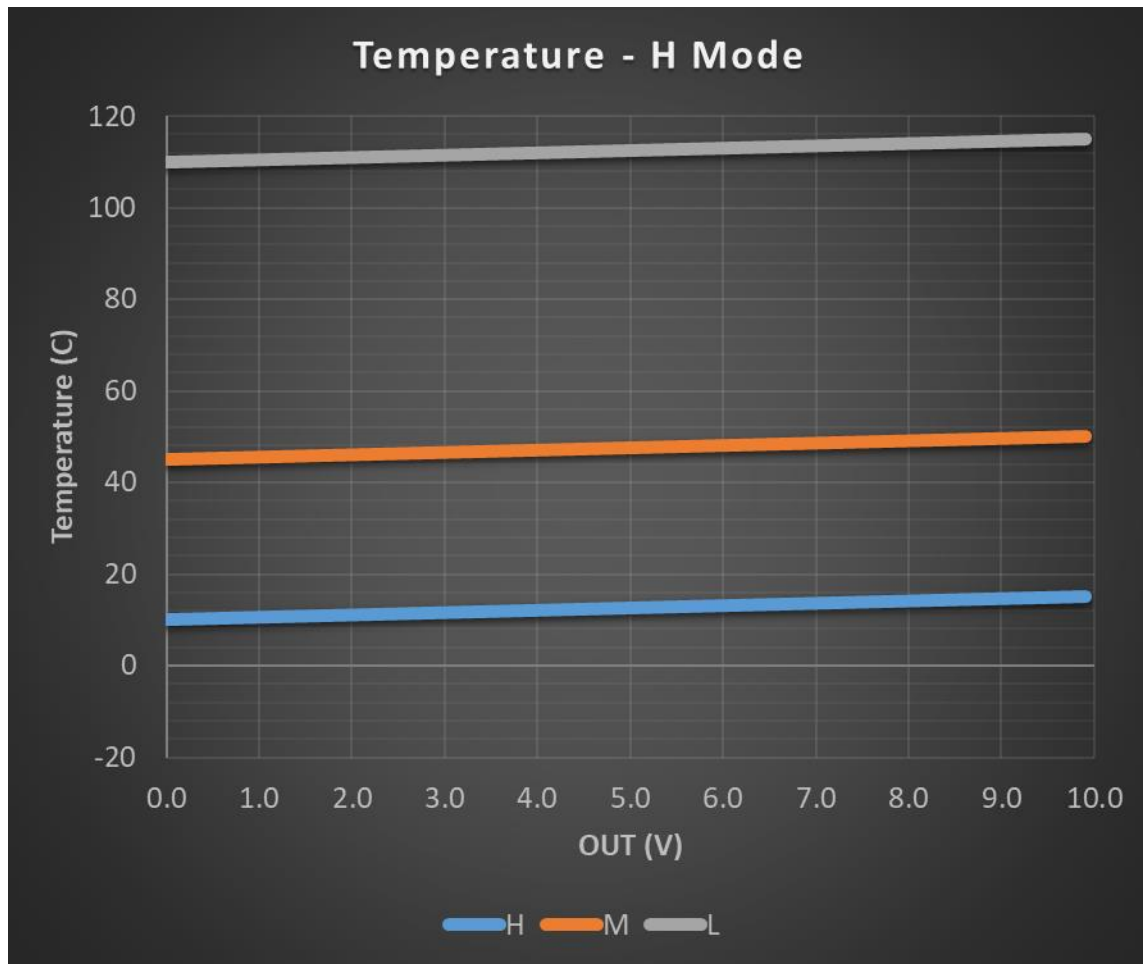

2 Temperature H Digital Mode for H, M, and L Sensitivities

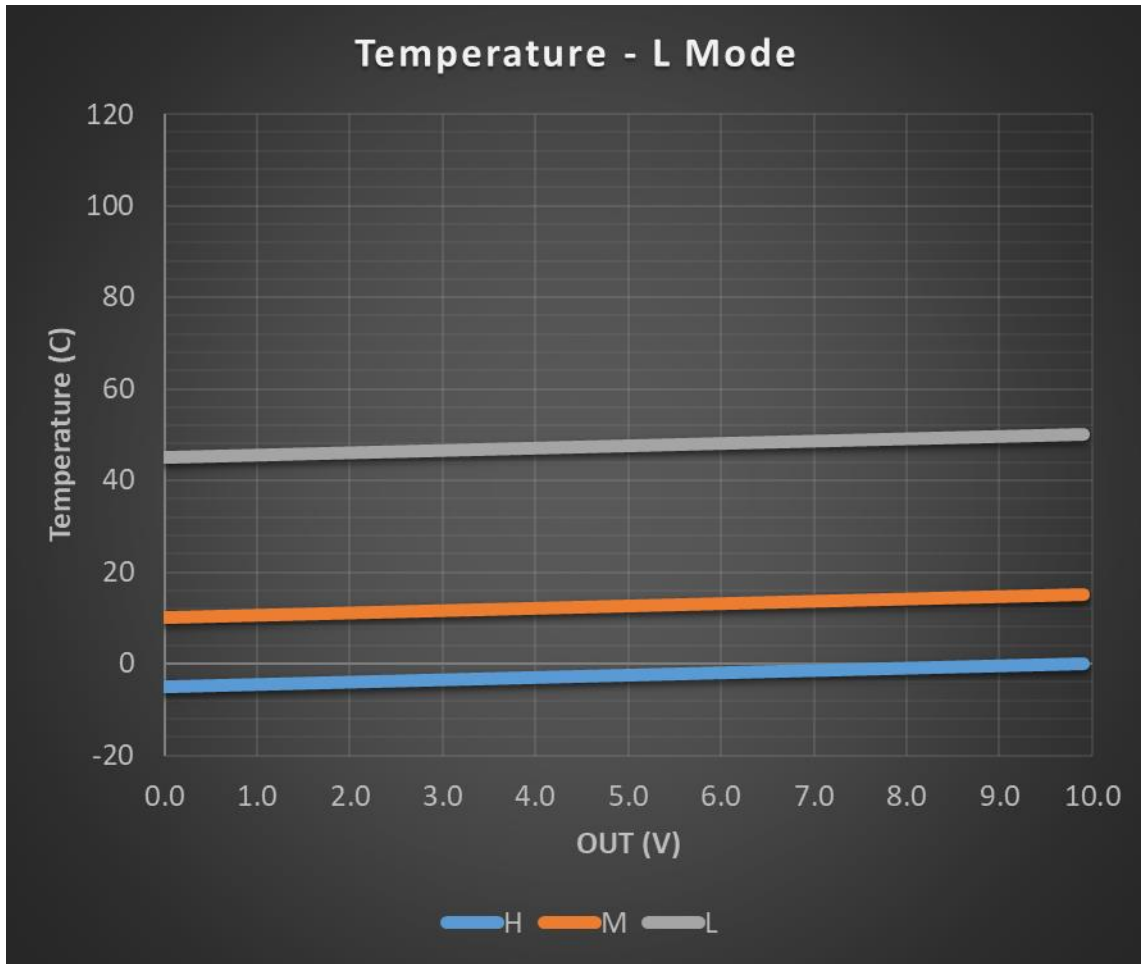

*3 Temperature L Digital Mode for H, M, and L Sensitivities*

## Product Features and Installation

The product is a small plastic enclosure that can be wall or ceiling mounted. The back mounting plate is removable. Separate the front housing from the back mounting plate. Then use screws or adhesive to secure the plate to the ceiling or wall surface. Reattach the front housing to the back mounting plate. The two pieces snap together without extra screws.

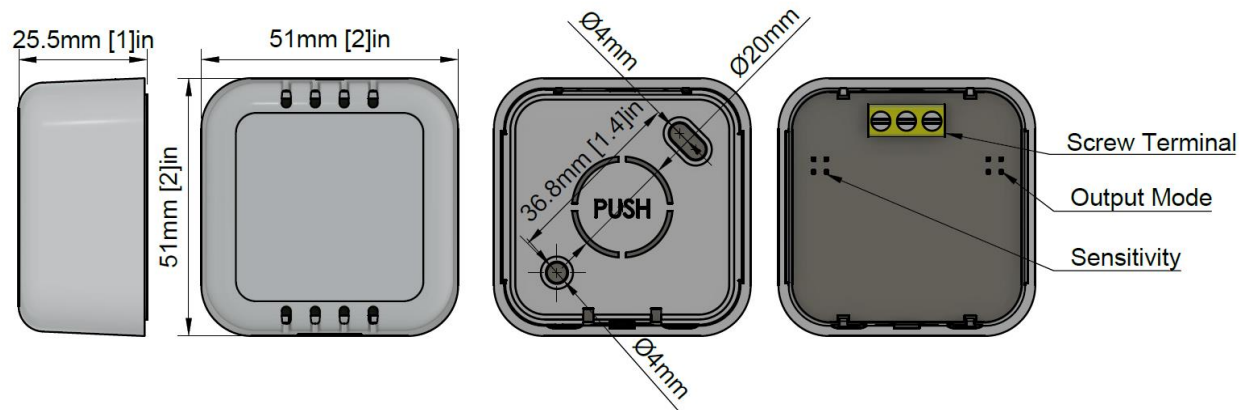

4 Product Dimensions and Features

## Sensitivity and Output Mode

The sensitivity and output modes can be changed by moving a jumper between header pins. There are 3 options for sensitivity.

<b>H</b>	High sensitivity
<b>M</b>	Medium
<b>L</b>	Low

And there are 3 options for output mode. In analog mode the output varies continuously in proportion to the motion speed. For digital modes the signal is active high which would be 10V when high temperature is detected and 0V for a low temperature.

<b>Analog</b>	continuously varying output signal between 0 and 10V
<b>H</b>	Digital high threshold, trigger at half scale (i.e. 5V)
<b>L</b>	Digital low threshold, trigger at quarter scale (i.e. 2.5V)

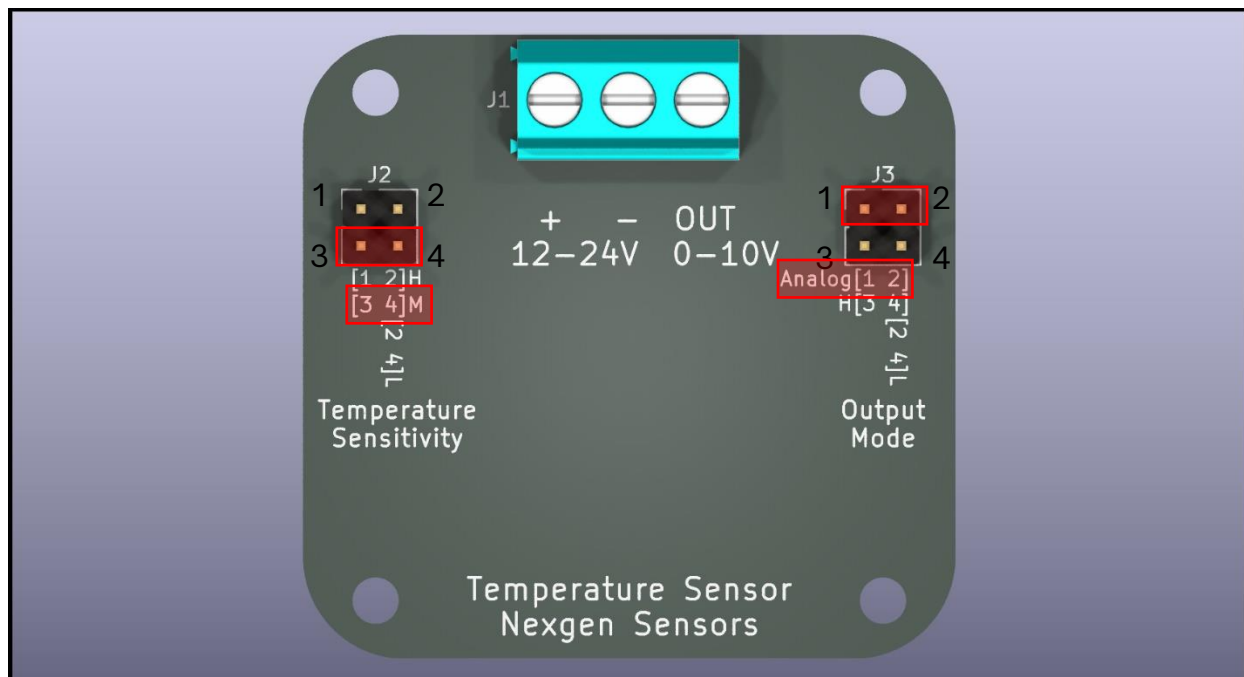

5 Sensitivity and Output Mode Adjustment

## Usage and Wiring

Connect the sensor to an existing controller, gateway, or data acquisition unit (DAQ). Provide a DC supply of 12-24V with at least 50mA. Use appropriate wires or cabling. Conductors can be solid or stranded 14-26 AWG. Secure the conductors to the 3 pins of the screw terminals.

- + Positive Supply, connect to 12-24V
- Negative Supply and signal return, connect to ground or common

**OUT** Sensor Signal, connect to input of controller, gateway, or DAQ

Multiple sensors can be wired in parallel. Each output has a series blocking diode. The largest signal is detected by the controller. This is useful for extending the sensing range or observing a larger area.

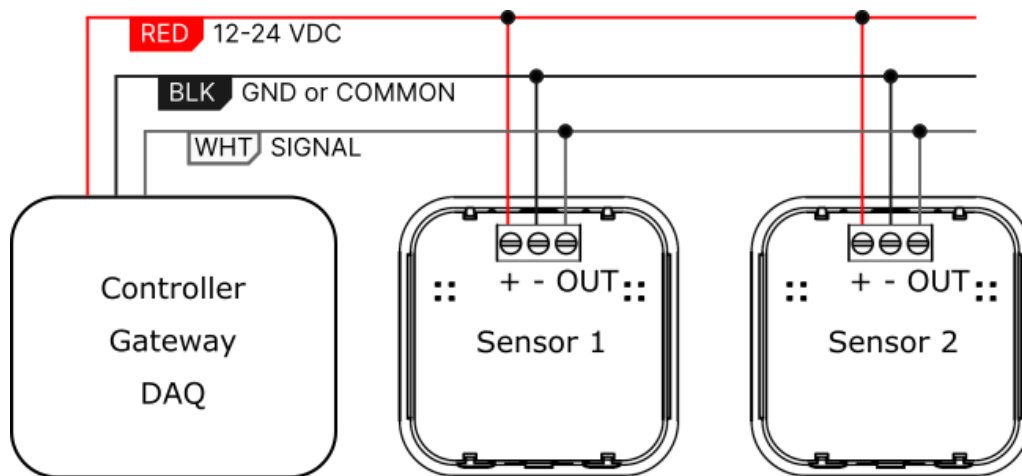

*6 Sensor Wiring Diagram*