

NS118 Distance

Analog mmWave Distance Sensor

- 24GHz mmWave Distance Monitor
- Human Presence Detection
- 0-10V Analog or Digital Output
- Adjustable Sensitivity
- 12-24V 50mA DC Supply
- 3 Wire Screw Terminal



Overview

The NS118 Distance sensor is a simple low voltage analog 24GHz mmWave distance and human presence detector. It can easily integrate into an existing building control system. Connect the sensor output signal to an analog input of a controller, gateway, or data acquisition unit. The distance or presence signal can be used for occupancy or intrusion detection. Whereas the raw distance signal could be used to continuously monitor distance to the nearest objects entering, residing, and leaving a space.

Operation

The mmWave distance sensor can detect relative distance to objects within a field of view. It is not limited to moving objects or body temperature like passive infrared. The device is suitable for ceiling or wall mount applications. Place the sensor in a suitable location where object distance should be detected.

The sensitivity can be adjusted with a simple jumper position. This selection changes the gain of an analog amplifier. Choose a gain suitable for typical distance range. A high gain will detect lower levels. Whereas a lower gain will minimize noise in the signal.

The output mode can be changed from a continuously varying analog signal to a digital signal. The digital signal is produced by a comparator with a threshold at half scale (i.e. 5V) or quarter scale (i.e. 2.5V). Use the analog mode to continuously monitor levels. Or use the digital mode to trigger actuators at a specific event threshold.

Changing the sensitivity and choosing the digital output scale can adjust the event threshold. Setting sensitivity high and digital scale low will reduce the event threshold to a minimum and detect the smallest changes in levels. Whereas, setting sensitivity low and digital scale high will increase the threshold to a maximum and detect only the largest changes in levels.

Detection Level

The distance detection level can be analog for applications requiring continuous monitoring of nearest objects. Such an application could be occupancy detection or even intrusion detection. A high or low distance level could also indicate door closure or an object that has been moved or fallen.

Digital output modes are also available. These modes set specific event thresholds. Use these to trigger an actuator if a distance changes.

The Presence mode sets the output high when human occupancy is detected. Note the presence mode output will saturate depending on the sensitivity selection. Typically, select H sensitivity in Presence mode.

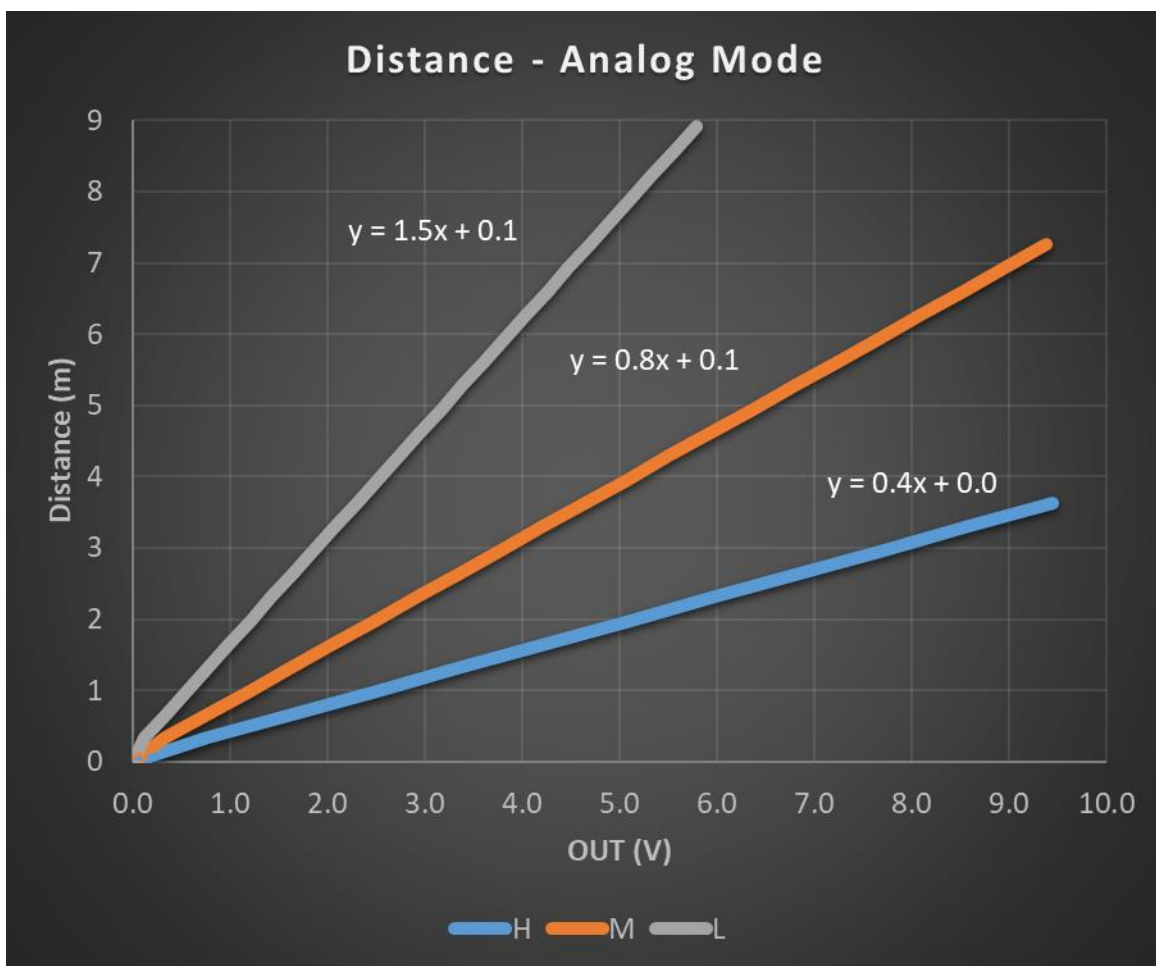

1 Distance Analog Mode for H, M, and L Sensitivities

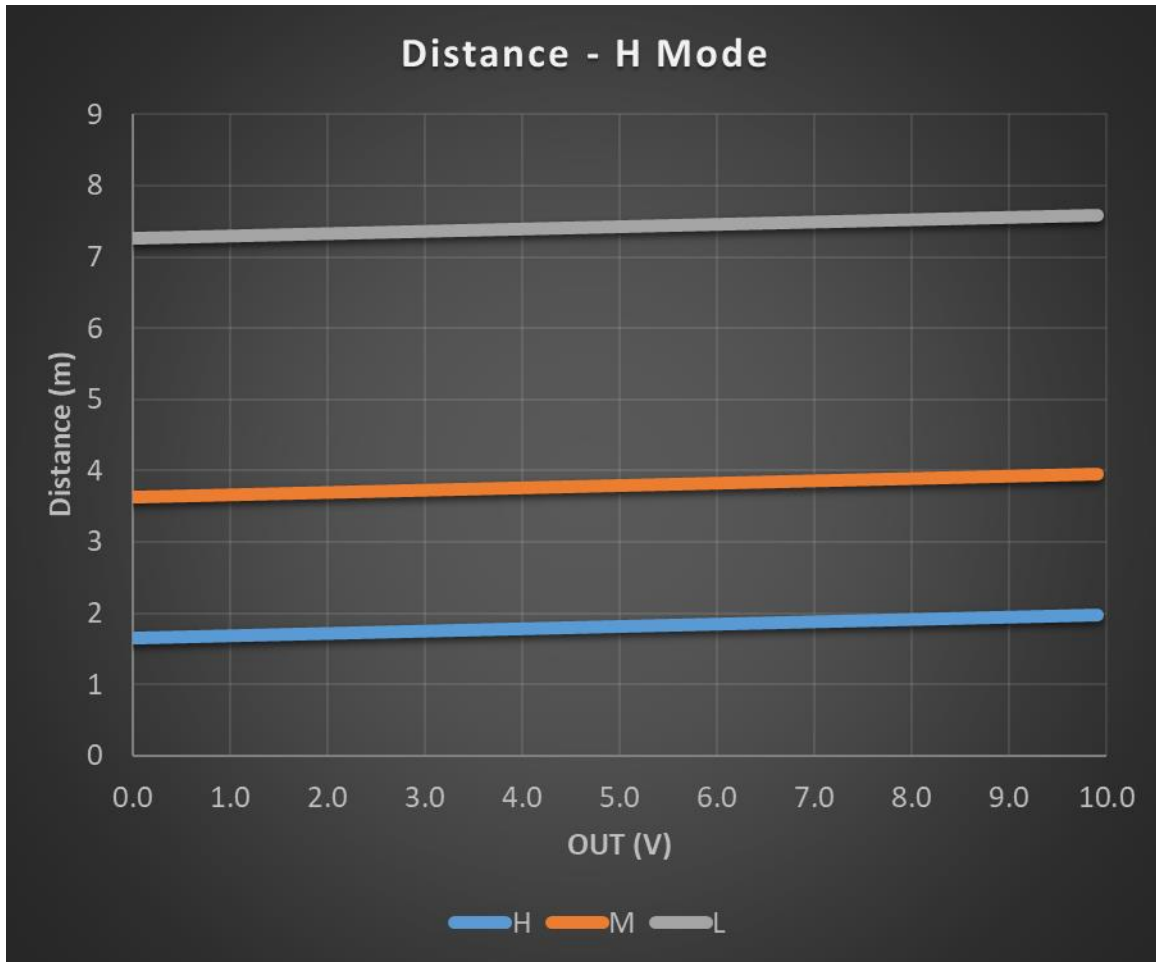

2 Distance H Digital Mode for H, M, and L Sensitivities

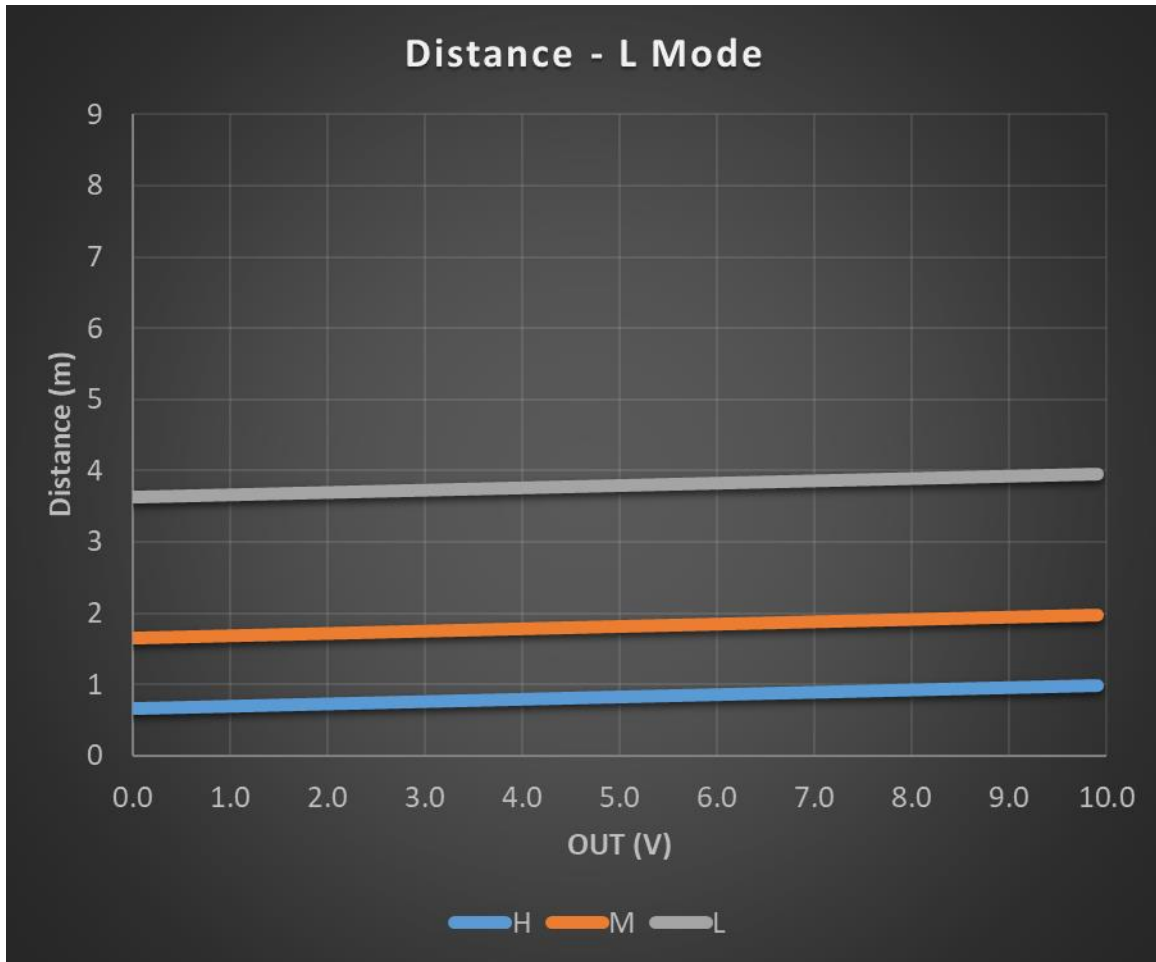

3 Distance L Digital Mode for H, M, and L Sensitivities

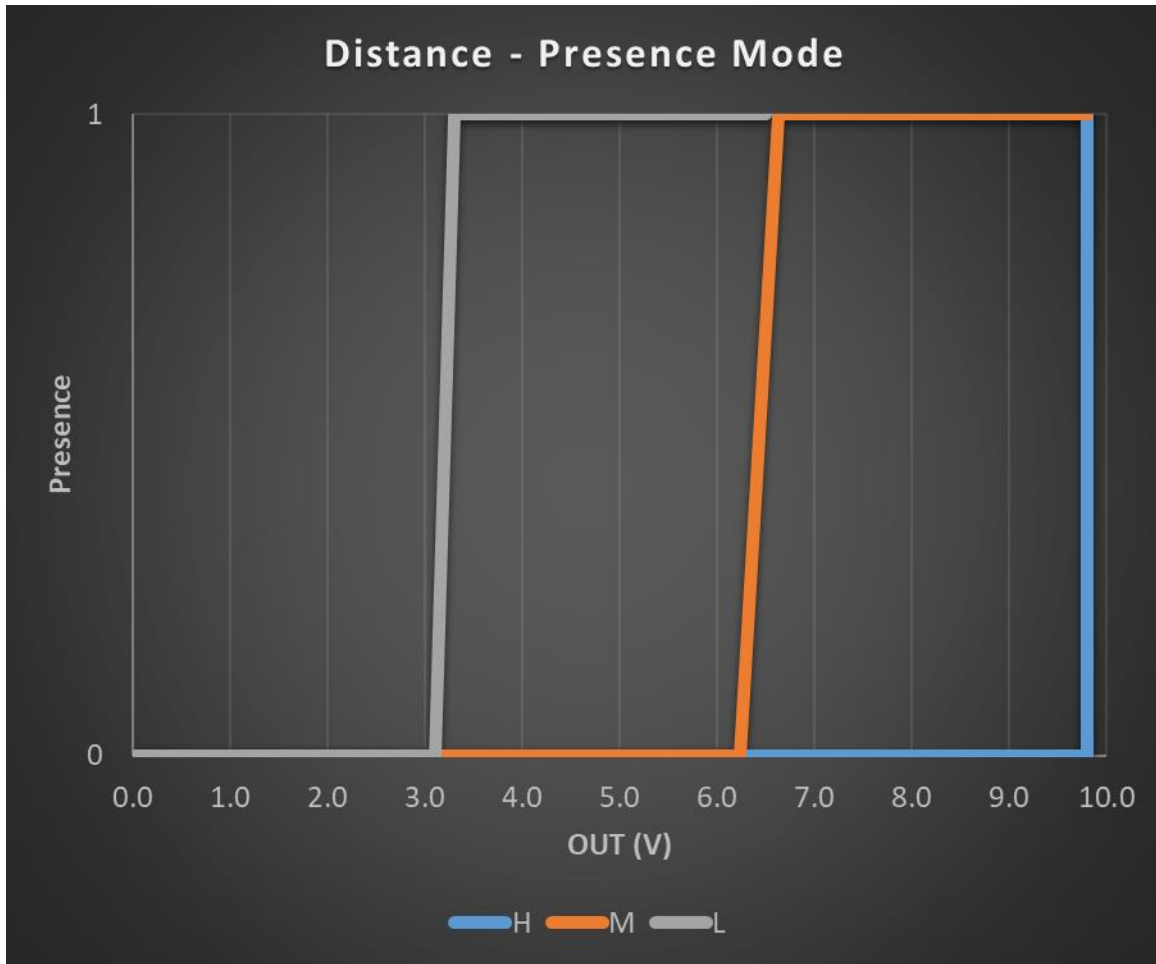

4 Distance Presence Mode for H, M, and L Sensitivities

Product Features and Installation

The product is a small plastic enclosure that can be wall or ceiling mounted. The back mounting plate is removable. Separate the front housing from the back mounting plate. Then use screws or adhesive to secure the plate to the ceiling or wall surface. Reattach the front housing to the back mounting plate. The two pieces snap together without extra screws.

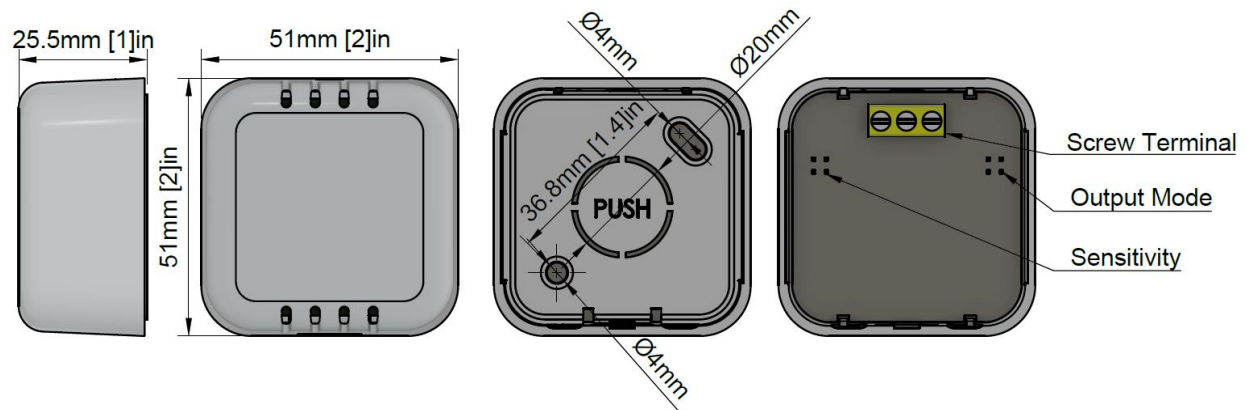

5 Product Dimensions and Features

Sensitivity and Output Mode

The sensitivity and output modes can be changed by moving a jumper between header pins. There are 3 options for sensitivity.

H	High sensitivity
M	Medium
L	Low

And there are 3 options for output mode. In analog mode the output varies continuously in proportion to the distance level. For digital modes the signal is active high which would be 10V when high distance is detected and 0V for a low distance.

Analog	continuously varying output signal between 0 and 10V
H	Digital high threshold, trigger at half scale (i.e. 5V)
L	Digital low threshold, trigger at quarter scale (i.e. 2.5V)

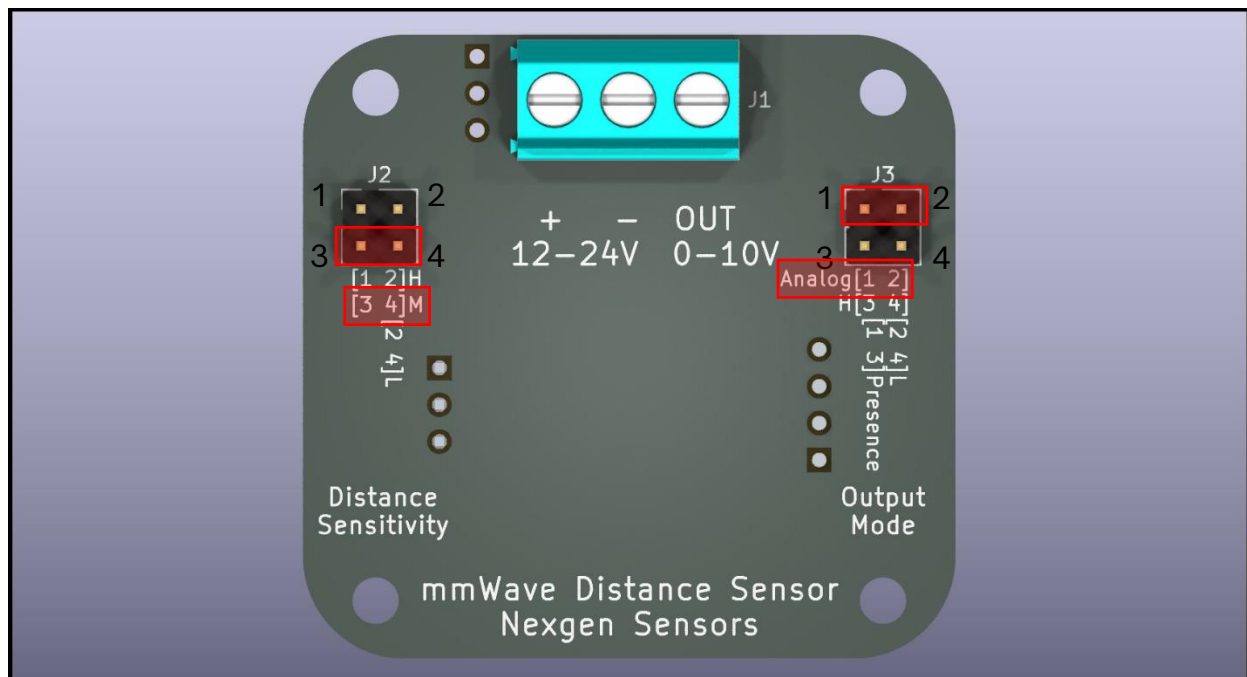

6 Sensitivity and Output Mode Adjustment

Usage and Wiring

Connect the sensor to an existing controller, gateway, or data acquisition unit (DAQ). Provide a DC supply of 12-24V with at least 50mA. Use appropriate wires or cabling. Conductors can be solid or stranded 14-26 AWG. Secure the conductors to the 3 pins of the screw terminals.

- + Positive Supply, connect to 12-24V
- Negative Supply and signal return, connect to ground or common

OUT Sensor Signal, connect to input of controller, gateway, or DAQ

Multiple sensors can be wired in parallel. Each output has a series blocking diode. The largest signal is detected by the controller. This is useful for extending the sensing range or observing a larger area.

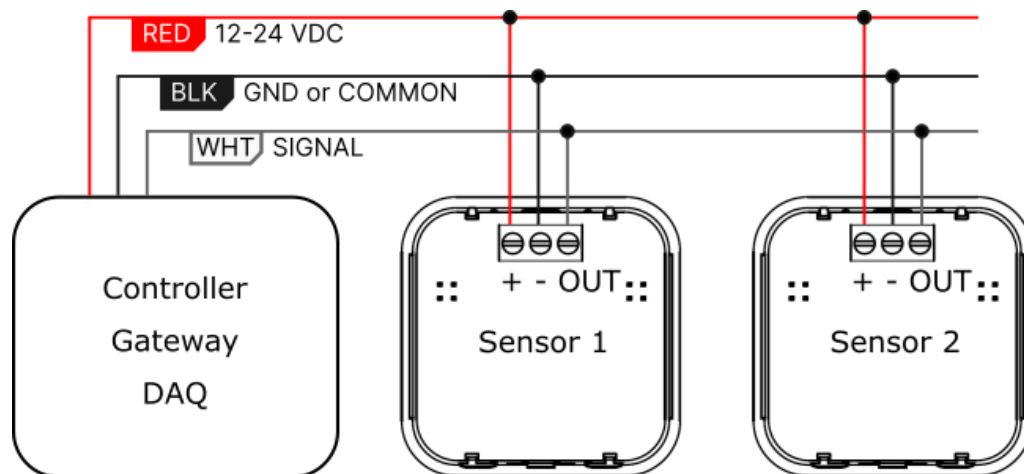

7 Sensor Wiring Diagram