

NS212 2 Button Up Down Wall Switch

Analog Push Button Wall Control

- 2 Tactile Momentary Switches
- Green LED Indicator
- 0-10V Analog Output
- 12-24V 10mA DC Supply
- 3 Wire Screw Terminal

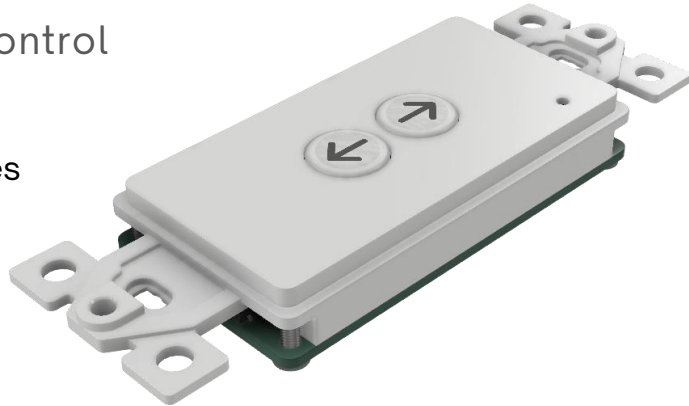

Overview

The NS212 2 Button Up Down Wall Switch is a simple low voltage analog wall control. It can easily integrate into an existing building control system. Connect the wall switch output signal to an analog input of a controller, gateway, or data acquisition unit. The analog voltage level indicates which button is pressed.

Operation

Press any of the function buttons to drive the analog output voltage to a specified level. Measure this voltage at the acquisition unit to decode which button is pressed. The effect is momentary. The signal will be at the specified voltage while the button is pressed. The output will drop to 0V or otherwise be high impedance when all buttons are released. A pull-down resistance of 10-100kOhm at the acquisition unit input is recommended to detect the released state.

Pressing multiple buttons can produce intermediate voltage levels and falsely indicate a button. While no harm is caused by multiple buttons pressed, it is recommended to press only one button at a time.

The buttons are electro-mechanical switches. A debounce time of 50ms is recommended. Input impedance of the acquisition unit and cable impedance can cause ringing. A low pass filter is recommended.

The Green LED indicator will be on when a button is pressed. It will turn off when the button is released.

Detection Levels

The button detection levels are separated by 1V with a tolerance $\pm 0.5V$. Measure the analog voltage and decode the button press by the following table. The analog output voltage will be driven to the described level for each button pressed. Pressing multiple buttons might causes unexpected voltages. Pressing a single button will yield an unambiguous level. Releasing the button will open circuit the output signal. If the acquisition unit input is adequately terminated with a pull-down resistor, the open circuit level will drop to 0V. Hence, 0V indicates no button is pressed.

Button	Voltage (V)
Up	5.0
Down	6.0
	$\pm 0.5V$

1 Button Detection Levels

Product Features and Installation

The product is a low voltage rectangular wall switch. Mount to a standard single gang North American electrical junction box. The junction box can be metallic or non-metallic. For metallic box provide adequate isolation. Grounding the low voltage system should be managed separately. Do not mix low voltage wiring with high voltage circuit. Cover with a standard rectangular wall switch face plate.

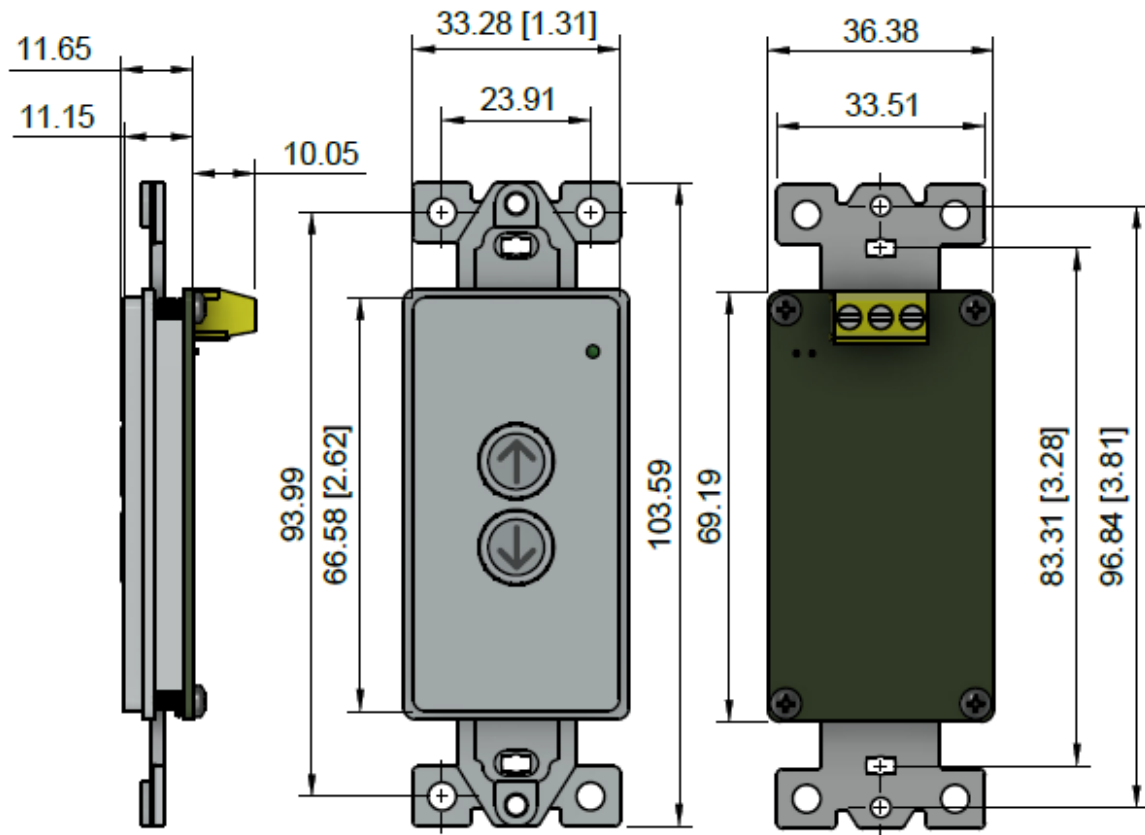

2 Product Dimensions and Features

Sensitivity and Output Mode

No adjustment is necessary. Sensitivity and output mode are fixed to the detection levels. The sensitivity is 1V resolution with +/-0.5V tolerance. The output mode is analog.



3 Sensitivity and Output Mode Adjustment

Usage and Wiring

Connect the wall switch to an existing controller, gateway, or data acquisition unit (DAQ). Provide a DC supply of 12-24V with at least 10mA. Use appropriate wires or cabling. Conductors can be solid or stranded 14-26 AWG. Secure the conductors to the 3 pins of the screw terminals.

- + Positive Supply, connect to 12-24V
 - Negative Supply and signal return, connect to ground or common
- OUT** Control Signal, connect to input of controller, gateway, or DAQ

Multiple wall switches and sensors can be wired in parallel. Each output has a series blocking diode. The largest signal is detected by the controller. This is useful for extending the control area, sensing range or observing a larger area.

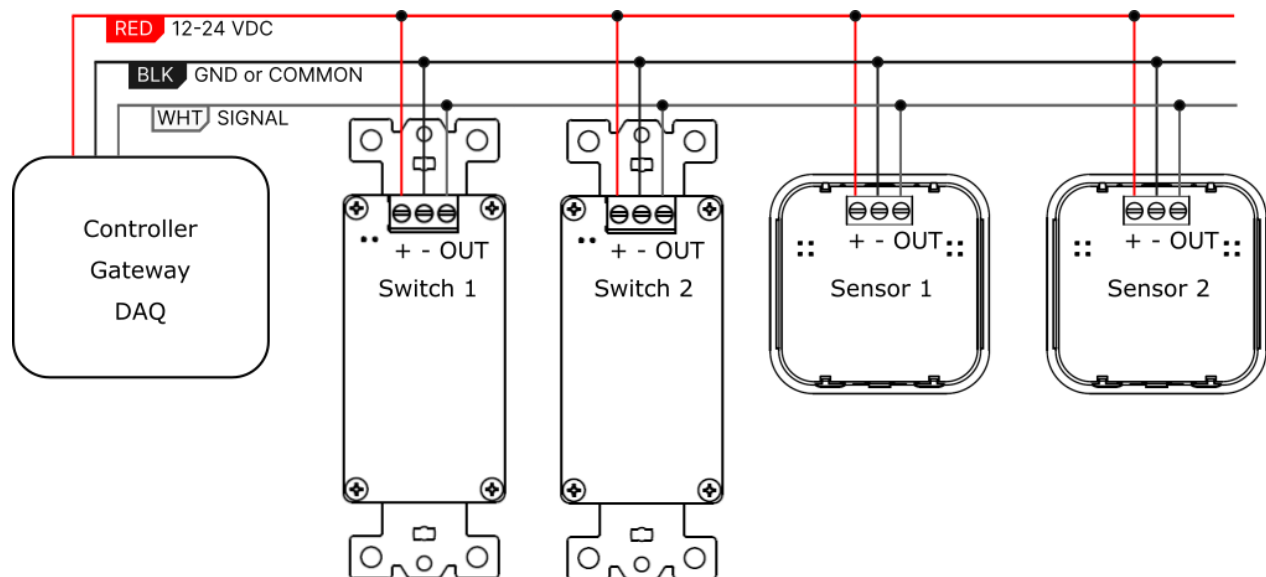

4 Wall Switch Wiring Diagram