

# NS110 Motion

## Analog PIR Motion Sensor

- 4 Quadrant PIR Detector
- 360-degree Fresnel Lens
- 0-10V Analog or Digital Output
- Adjustable Sensitivity
- LED Indicator On/Off
- 12-24V 50mA DC Supply
- 3 Wire Screw Terminal



## Overview

The NS110 Motion sensor is a simple low voltage analog passive infrared (PIR) detector. It can easily integrate into an existing building control system. Connect the sensor output signal to an analog input of a controller, gateway, or data acquisition unit. The motion signal can be used to detect occupancy or even continuously monitor speed of moving objects occupying a space.

## Operation

The sensor can detect the movement of warm objects such as humans occupying a space. The field of view is 360 degrees which is suitable for ceiling or wall mount application. Place the sensor in a suitable location with line of sight to areas where motion should be detected.

The sensitivity can be adjusted with a simple jumper position. This selection changes the gain of an analog amplifier. Choose a gain suitable for typical speed or distance of motion objects. A high gain will detect slower or more distant objects. Whereas a lower gain will minimize noise in the signal.

The output mode can be changed from a continuously varying analog signal to a digital signal. The digital signal indicates motion when high and lack of motion when low. If enabled the LED indicator will be on when motion is detected and off otherwise.

Changing the sensitivity and choosing the digital output scale can adjust the motion speed threshold. Setting sensitivity high and digital scale low will reduce the speed threshold to a minimum and detect the smallest changes by slow or distant objects.

## Detection Range

The detection range can exceed 9m (30ft) where the field of view is unobstructed. The 360-degree Fresnel Lens has a radial pattern with sections of higher sensitivity. Generally, this is suitable for objects moving across these sensitivity sections. However, detection can fail if the object is stationary or has limited movement. For example, a human occupant that is sitting might not be detected.

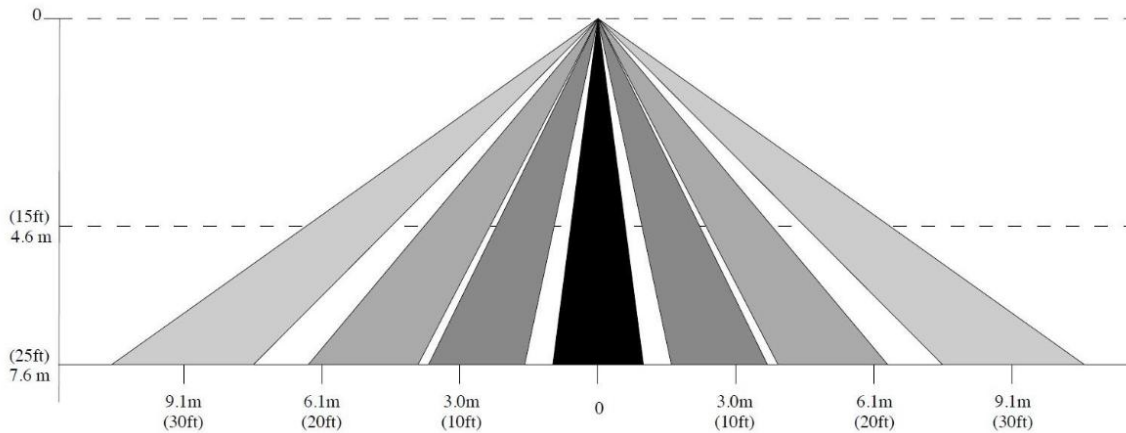

1 Fresnel Lens Beam Pattern

## Product Features and Installation

The product is a small plastic enclosure that can be wall or ceiling mounted. The back mounting plate is removable. Separate the front housing from the back mounting plate. Then use screws or adhesive to secure the plate to the ceiling or wall surface. Reattach the front housing to the back mounting plate. The two pieces snap together without extra screws.

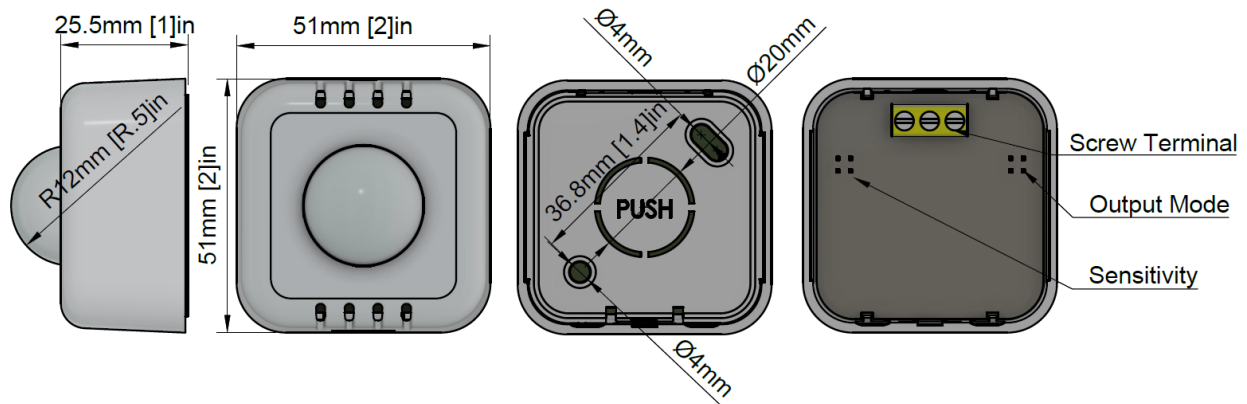

2 Product Dimensions and Features

## Sensitivity and Output Mode

The sensitivity and output modes can be changed by moving a jumper between header pins. There are 3 options for sensitivity.

<b>H</b>	High sensitivity
<b>M</b>	Medium
<b>L</b>	Low

And there are 3 options for output mode. In analog mode the output varies continuously in proportion to the motion speed. For digital modes the signal is active high which would be 10V when motion is detect and 0V without motion.

<b>Analog</b>	continuously varying output signal between 0 and 10V – LED On with motion
<b>H</b>	Digital – LED On with motion
<b>L</b>	Digital – LED Off

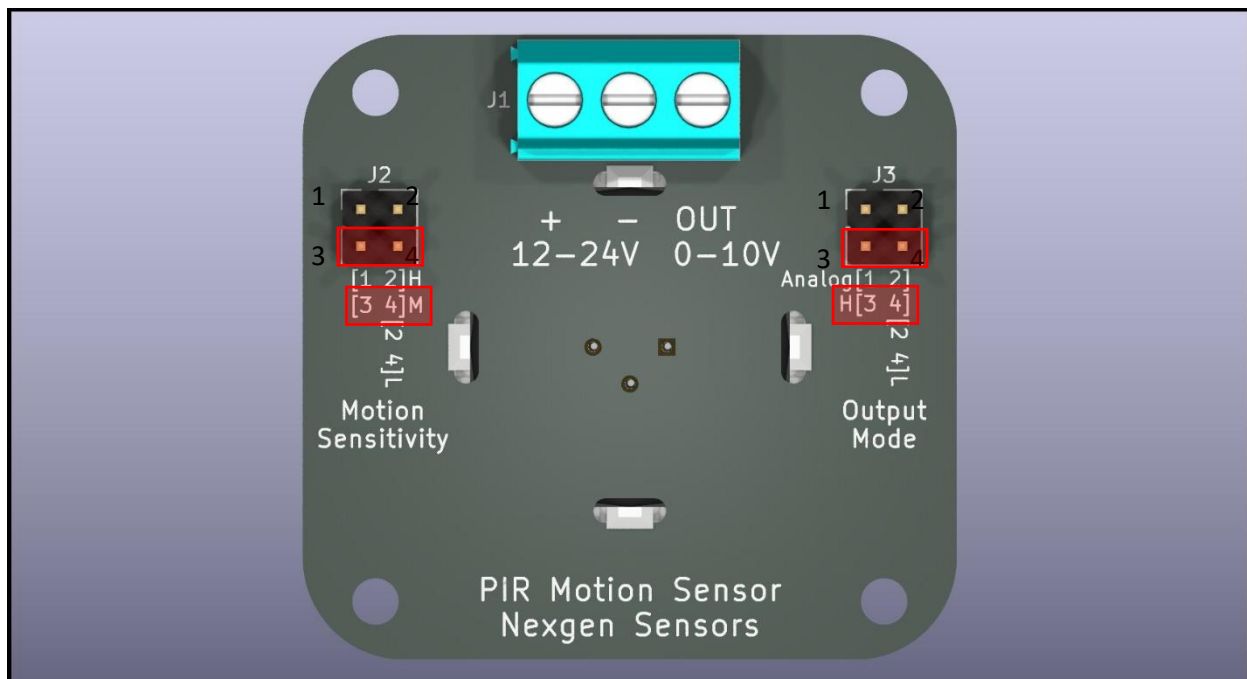

*3 Sensitivity and Output Mode Adjustment*

## Usage and Wiring

Connect the sensor to an existing controller, gateway, or data acquisition unit (DAQ). Provide a DC supply of 12-24V with at least 50mA. Use appropriate wires or cabling. Conductors can be solid or stranded 14-26 AWG. Secure the conductors to the 3 pins of the screw terminals.

- + Positive Supply, connect to 12-24V
- Negative Supply and signal return, connect to ground or common
- OUT** Sensor Signal, connect to input of controller, gateway, or DAQ

Multiple sensors can be wired in parallel. Each output has a series blocking diode. The largest signal is detected by the controller. This is useful for extending the sensing range or observing a larger area.

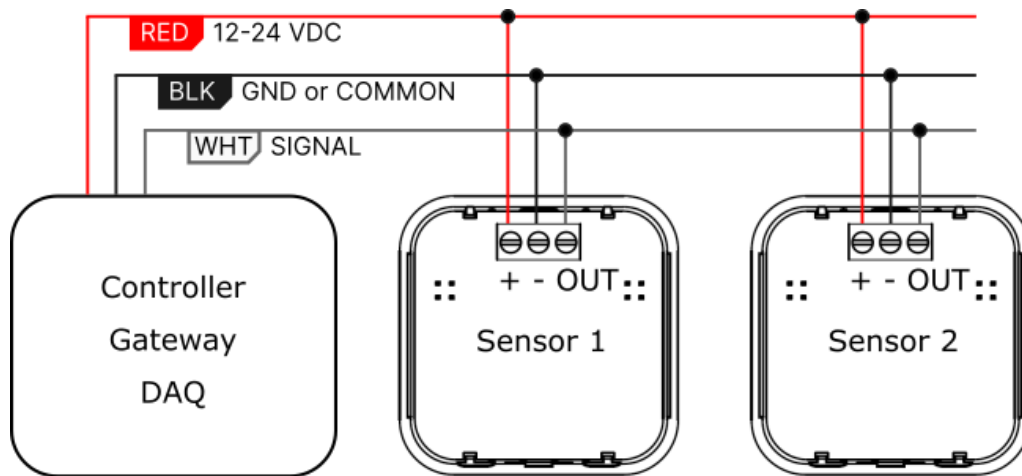

4 Sensor Wiring Diagram