

NS311 Thermal Occupancy Multi

Digital Infrared Imaging Sensor and Controller

- 32x24 Thermal Imaging Sensor
- Light Sensor
- PM 1.0/2.5/10 Laser Particle Counter
- Total VOC Measurement
- Stereo Microphones
- Temperature, Humidity
- RS485 Digital Output
- Wi-Fi HTTPS/MQTT
- 5-60V DC Supply
- 0-10V Programmable Input/Output
- 12V DC Output
- 4 Wire Screw Terminals



Overview

The NS311 Thermal Occupancy Multi sensor is an advanced low voltage multi sensor digital occupancy controller. It features thermal imaging, light sensing, air particulate matter and multi-gas detection, sound monitoring and language processing. It can easily integrate into an existing building control system. Connect the sensor output signal to an RS485 transceiver of a controller, gateway, or data acquisition unit. Or provision for an existing Wi-Fi network for wireless connectivity.

Operation

The NS311 continuously gathers data from its environment, processes it, and transmits it via wired or wireless communication channels. It also provides control input-output for integrating with other systems. This multifaceted functionality enables a wide range of applications in building automation, environmental monitoring, and occupancy management.

Occupancy Detection:

- The core function relies on a 32x24 thermal imaging sensor. This sensor captures heat signatures within its field of view, enabling it to detect the presence and movement of people.
- The device processes the thermal data to determine occupancy levels, providing real-time information on the number of individuals present in the monitored space.

Environmental Monitoring:

- **Air Quality:**
 - **Particulate Matter (PM) Measurement:**
 - A laser particle counter measures particulate matter (PM) concentrations, specifically PM 1.0, PM 2.5, and PM 10, providing data on airborne particle levels.
 - This data is used in conjunction with VOC measurement to detect potential vaping events.
 - **Total Volatile Organic Compound (TVOC) Measurement:**
 - A Total Volatile Organic Compound (TVOC) sensor monitors the concentration of various gases, indicating overall air quality.
 - This data is used in conjunction with PM measurement to detect potential vaping events.
 - **Vaping Detection:**
 - The sensor analyses the data from the PM and VOC sensors to detect rapid increases in both PM and VOC concentrations, that indicate a potential vaping event.
 - The sensor analyses the duration of elevated PM2.5 levels to filter out short-lived particle fluctuations that may be caused by other sources.
 - The sensor will set the VapingDetected logical state to True, when a possible vaping event is detected.
 - The VapingDetected parameter should be used with caution, as it relies on indirect indicators and may produce false positives.
- **Temperature and Humidity:** Integrated sensors continuously measure ambient temperature and relative humidity, providing data for environmental control.
- **Light Sensing:** A light sensor measures ambient light levels, enabling applications such as automated lighting control.

Sound Monitoring and Language Processing:

- Stereo microphones capture audio within the sensor's range.
- The device processes audio data, potentially for sound level monitoring, or advanced language processing for voice commands, or anomaly detection.

Data Communication and Control:

- **RS485 Digital Output:** The sensor transmits data via an RS485 interface, allowing for wired integration with building management systems (BMS), controllers, gateways, or data acquisition units.
- **Wi-Fi Connectivity:** The sensor supports Wi-Fi connectivity, enabling wireless data transmission via HTTPS or MQTT protocols. This allows for remote monitoring and control over a network.
- **0-10V Programmable Input/Output:** The sensor features a 0-10V programmable input/output, enabling it to control external devices or receive analog signals from other sensors.
- **12V DC Output:** The device provides a 12V DC output, that can be used to power other low voltage devices.

Power Supply:

- The sensor operates on a 5-60V DC power supply, providing flexibility for various installation environments.
- 4 wire screw terminals provide the electrical connections.

Thermal Imaging

The NS311 utilizes a 32x24 pixel thermal imaging sensor to detect and analyze heat signatures within its field of view. This technology enables accurate occupancy detection and provides valuable insights into the thermal dynamics of the monitored environment.

Key Features:

- **High Sensitivity:** The sensor can detect subtle temperature differences, allowing for reliable detection of human presence even in low-light or obscured conditions.
- **Real-Time Occupancy Detection:** By analyzing the thermal patterns, the NS311 can accurately determine the presence and movement of individuals within the monitored space.
- **People Counting:** The sensor's processing algorithms can estimate the number of people present in the area based on the detected thermal signatures.
- **Field of View:** The sensor's field of view 55 degrees by 35 degrees is designed to cover a substantial area, ensuring comprehensive monitoring of the target space at a sufficient resolution.

Operational Principle:

The thermal imaging sensor measures the infrared radiation emitted by objects within its field of view. This radiation is then converted into a temperature map, where warmer objects appear brighter and cooler objects appear darker. NS311's onboard processor analyzes this temperature map to identify patterns indicative of human presence.

Applications:

- Occupancy-based lighting and HVAC control
- Security and intrusion detection
- People counting and space utilization analysis
- Thermal monitoring of equipment and environments
- Elderly care monitoring.

The following example demonstrates NS311's ability to capture and interpret thermal signatures. In this image, the sensor clearly captures the heat signature of a person waving their arm. The warmer areas correspond to the person's body, while the cooler background is represented by darker shades. This real-time thermal data allows NS311 to detect movement and presence with high accuracy.

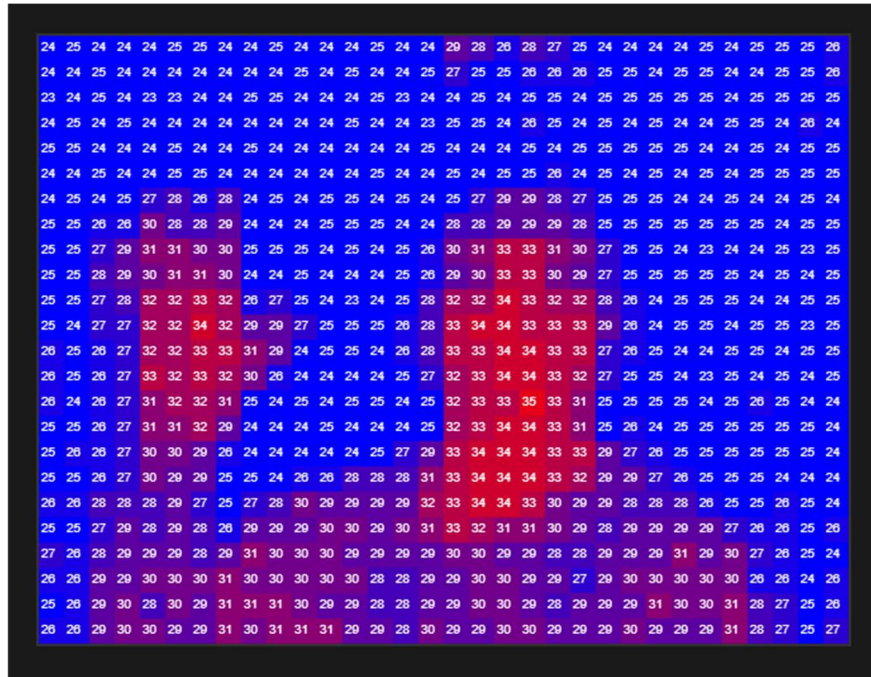

Figure 1 Thermal Image Viewer

Data Output:

The thermal imaging data can be accessed via NS311's digital output interfaces:

- **RS485:** The sensor transmits the thermal data as part of its ASCII message stream. The format of this data is [Specify the data format here, e.g., a series of temperature values, a compressed image representation].
- **Wi-Fi (HTTPS/MQTT):** Thermal data can be transmitted wirelessly using HTTPS or MQTT protocols.

Notes:

- The accuracy of people counting may be affected by factors such as overlapping thermal signatures and environmental conditions.
- The field of view of the sensor is designed to be optimal for most indoor environments.
- The sensor can detect heat signatures through some thin nonmetallic materials.

Particle Pollution Level

Fine particles are detected by the sensor. These particles cause air pollution hazards. Breathing unhealthy air can increase health risks. It is recommended to continuously monitor the particle pollution level. If the pollution exceeds healthy or safe levels notify occupants and advise maintenance or building controls to adjust ventilation and filtration. If possible, identify the source of the particle pollution and eliminate it.

Smaller particle sizes present a higher respiratory risk. The concentration range for each level of concern is reduced. More care should be taken to monitor and eliminate these smaller particles. Generally, air filtration can adequately reduce concentration to acceptable levels. Levels exceeding “Good” or “Moderate” should be addressed immediately. Inspect the air handling, filtration, and ventilation systems and repair any faulty components.

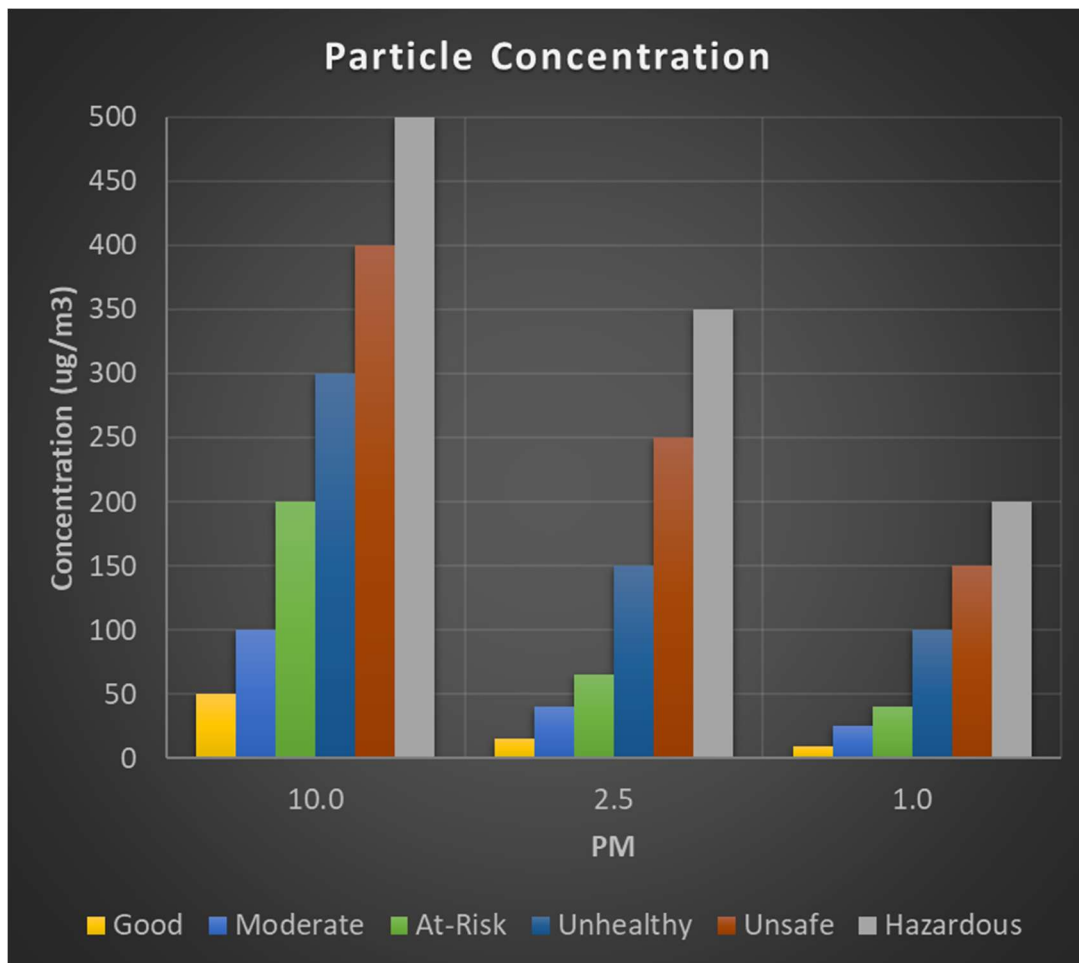

Figure 2 Particle Concentration Pollution Level by size

Total VOC Detection

Volatile organic compounds (VOCs) are up to five times more concentrated indoors than outdoor airspaces. These compounds are caused by human occupant’s respiration, transpiration, and other metabolic processes. Additionally, common building materials such as furniture, flooring, wall coverings can out-gas VOCs. Most commonly these compounds include ethanol, toluene, acetone among other solvents. These compounds can cause eye irritation, headache, drowsiness, dizziness, and other irregularities. Continuous monitoring and ventilation are recommended.

Total volatile organic compound (TVOC) is the summation of various gas species. The metal-oxide detector has different sensitivities to various species. For example, it is significantly more sensitive to smaller molecules like CO and H₂ than larger molecules like ethanol. Be advised that TVOC is an index of all pollutants and not a selective sensor for a particular gas species. If it is known that a particular gas species dominates an airspace, then selectivity might be significant. Use this sensor to detect the level of concern. But additional detection with more selective sensors might be necessary to find root cause.

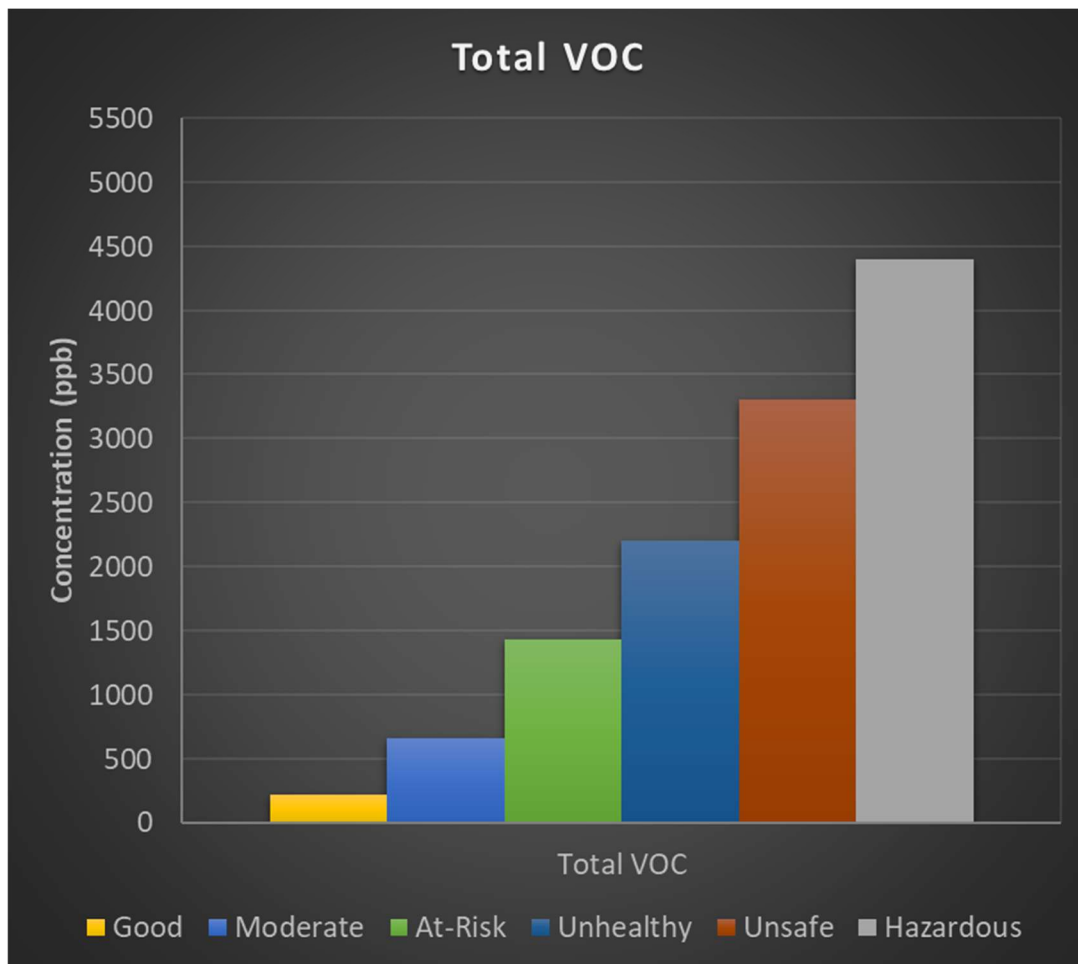

Figure 3 Total VOC Concentration Air Quality Levels

Vaping Detection

NS311 is equipped with advanced algorithms to detect potential vaping events within the monitored environment. This feature leverages the integrated PM 1.0/2.5/10 laser particle counter and the Total VOC (TVOC) sensor to identify anomalies indicative of vapor presence.

Operational Principle:

- **Particle Concentration Analysis:**
 - The sensor continuously monitors PM2.5 concentration levels.
 - Vaping events typically result in a rapid and significant increase in PM2.5 concentrations, as shown in the provided time-series graph.
 - NS311 detects these sudden spikes in particle concentration, comparing them to a predefined threshold.
- **Time-Based Anomaly Detection:**
 - A typical vaping event lasts for 10-20 seconds.
 - The sensor analyzes the duration of elevated PM2.5 levels to filter out short-lived particle fluctuations that may be caused by other sources.
- **VOC Correlation:**
 - To minimize false positives, the sensor correlates elevated PM2.5 levels with simultaneous increases in TVOC concentrations.
 - This combined analysis provides a more robust indication of vaping activity.

Vaping Response Signal:

- [Insert Time-Series Graph of PM2.5 Concentration and Vaping Response Signal Here]
- The graph clearly demonstrates the correlation between elevated PM2.5 concentrations and the sensor's "Vaping Response" signal.
- Normally, the particle concentration remains low. However, when vapor is introduced, the measured concentration increases dramatically.
- The sensor detects this anomaly and sets the "VapingDetected" logical state to "True."

Logical Output:

- **VapingDetected (boolean):** Indicates a potential vaping event based on the combined analysis of PM2.5 and TVOC data. (True/False).

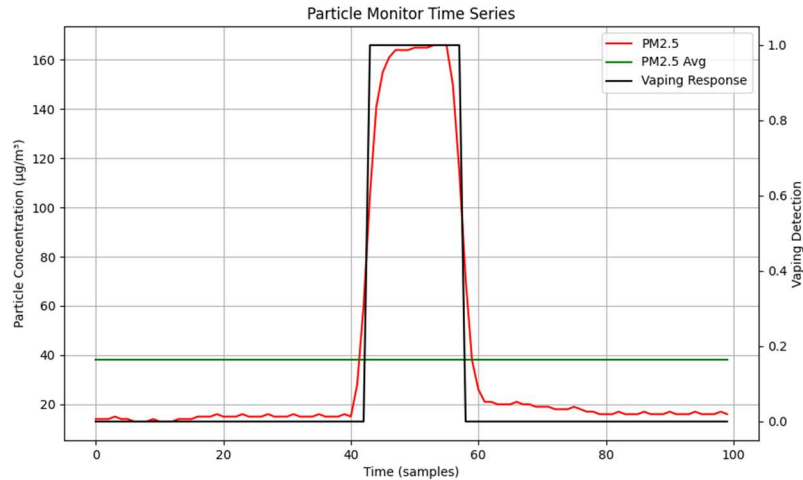

Figure 4 Time Series Response for Particle Concentration and Vaping Detection.

Notes:

- The "VapingDetected" relies on indirect indicators and may produce false positives.
- The algorithms used to determine a vaping event are designed to minimize false positives but may not be foolproof.
- Environmental factors can influence particle and VOC concentrations, and these factors should be considered when interpreting the sensor's output.

Product Features and Installation

The product is a small plastic enclosure that can be wall or ceiling mounted. The back mounting plate is removable. Separate the front housing from the back mounting plate. Then use screws or adhesive to secure the plate to the ceiling or wall surface. Reattach the front housing to the back mounting plate. The two pieces snap together without extra screws.

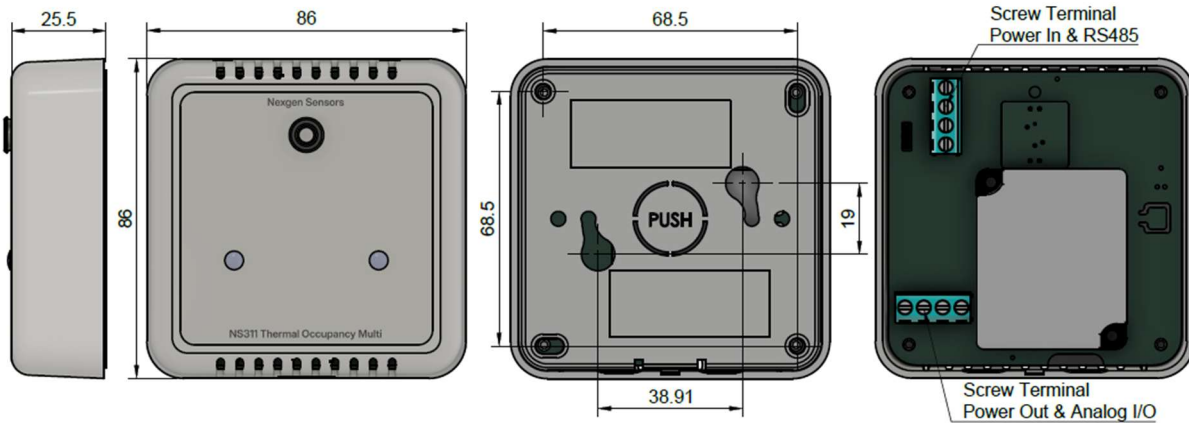

5 Product Dimensions and Features

Sensitivity, Output Mode and Type

The sensitivity for each type is described in previous sections:

- ug/m3 for PM10, PM2.5 and PM1 particle concentrations
- ppb for Total VOC (TVOC)
- C for temperature (T)
- % for relative humidity (RH)
- Thermal Imaging: 32x24 pixel resolution, capable of detecting temperature differences associated with human presence.
- Light Sensing: Measurement of ambient light intensity, providing relative lux values.
- Sound Monitoring: Stereo microphones capture audio within the sensor's range, capable of detecting sound levels and potentially processing audio for language detection or anomaly detection.

The output mode is digital

- RS485 115200 Baud
- Jumper 120Ohm terminator if required
- 10 second message period
- ASCII message, sensor, serial number, key-value pairs comma separated, carriage return line feed:

```
sensor NS311, hostname ns-xxxxxxx, PM10 xxx ug/m3, PM2.5 xxx ugm/3, PM1 xxx ug/m3,
TVOC xxxx ppb T xx.x C, RH xx.x %, ThermalImage data, LightLevel xxx, SoundLevel
xxx, Occupied boolean, PeopleCount integer, Keywords string, VapingDetected
boolean\r\n
```

- Wi-Fi HTTPS/MQTT

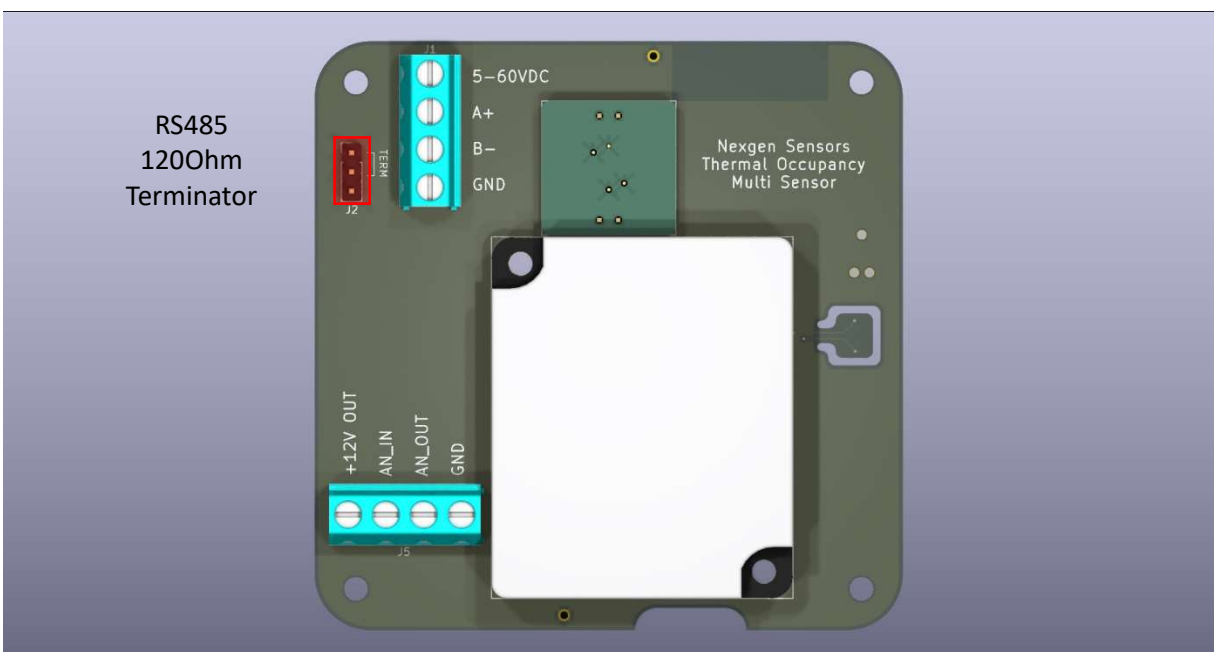

6 Sensitivity and Output Mode Adjustment and Measurement Type

Logical Parameters:

- **Occupied (boolean):** Indicates whether the sensor detects the presence of people in the monitored space. (True/False).
- **PeopleCount (integer):** Provides an estimated count of the number of individuals detected by the thermal imaging sensor.
- **Keywords (string):** If voice processing is implemented, this field contains any detected keywords or phrases.
- **VapingDetected (boolean):** Indicates a potential vaping event based on elevated particle counts and VOC levels. (True/False).

Usage and Wiring

Connect the sensor to an existing controller, gateway, or data acquisition unit (DAQ). Provide a DC supply of 5-60V with at least 3W. Use appropriate wires or cabling. Conductors can be solid or stranded 14-26 AWG. Secure the conductors to the 4 pins of the screw terminals.

5-60VDC	Positive Supply, connect to 5-60V
A+	RS485 A data signal
B-	RS485 B data signal
GND	Negative Supply and signal return, connect to ground or common

Multiple sensors can be wired in parallel. Identify each sensor by serial number. Associate the serial number to the installation location of the sensor. This is useful for extending the sensing range or observing a larger area.

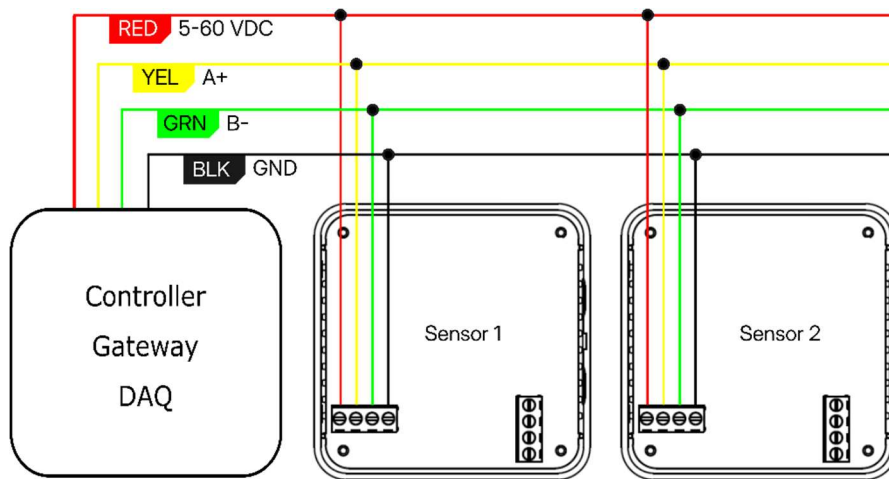

7 Sensor Wiring Diagram

Alternatively, the sensors can operate independently rather than connected to an external controller or gateway. And Wi-Fi connectivity can be used instead of a wired RS485 network. In this example the sensors connect to a local Wi-Fi access point for communication. They are powered by a simple external power supply. Additionally, external analog sensors or switches can be wired to the analog input terminal. And external alarms, indicators, or relays can be driven from the analog output terminal. A 12V DC supply is also provided at a screw terminal for powering the external devices with up to 200mA.

- 12VDC** Positive Output Supply, 12V/200mA for external devices
- AN_IN** 0-10V Analog Input, tolerant to 60V over-voltage
- AN_OUT** 0-10V Analog Output
- GND** Negative Supply and signal return, connect to ground or common

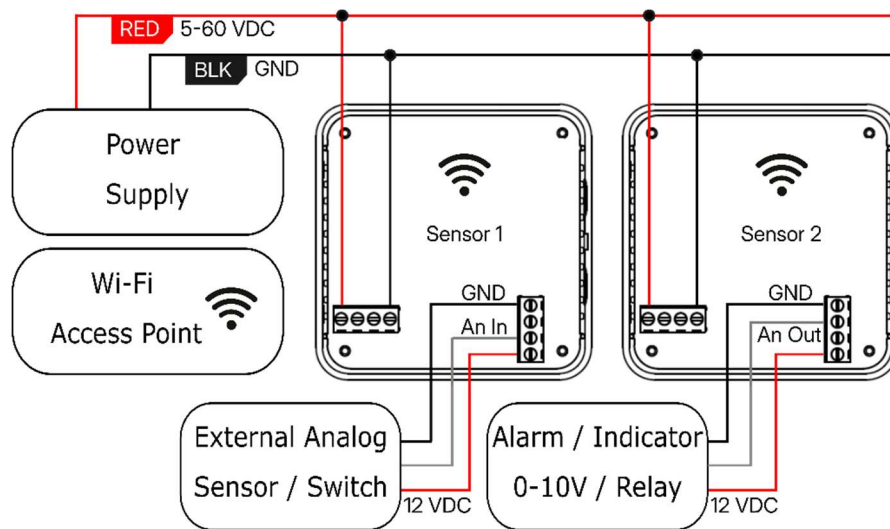

Figure 8 Wireless Network and Programmable Analog I/O Usage